

25MM Disassembly – Assembly Instructions

Disassembly

Tools Needed – SAI Separation Tool (P/N S830708) and a flat head screw driver. (Note: the separation tool is shown in blue and two links are shown in green and red this is for identification purposes associated with this document only and does not reflect the actual colors of these items.)

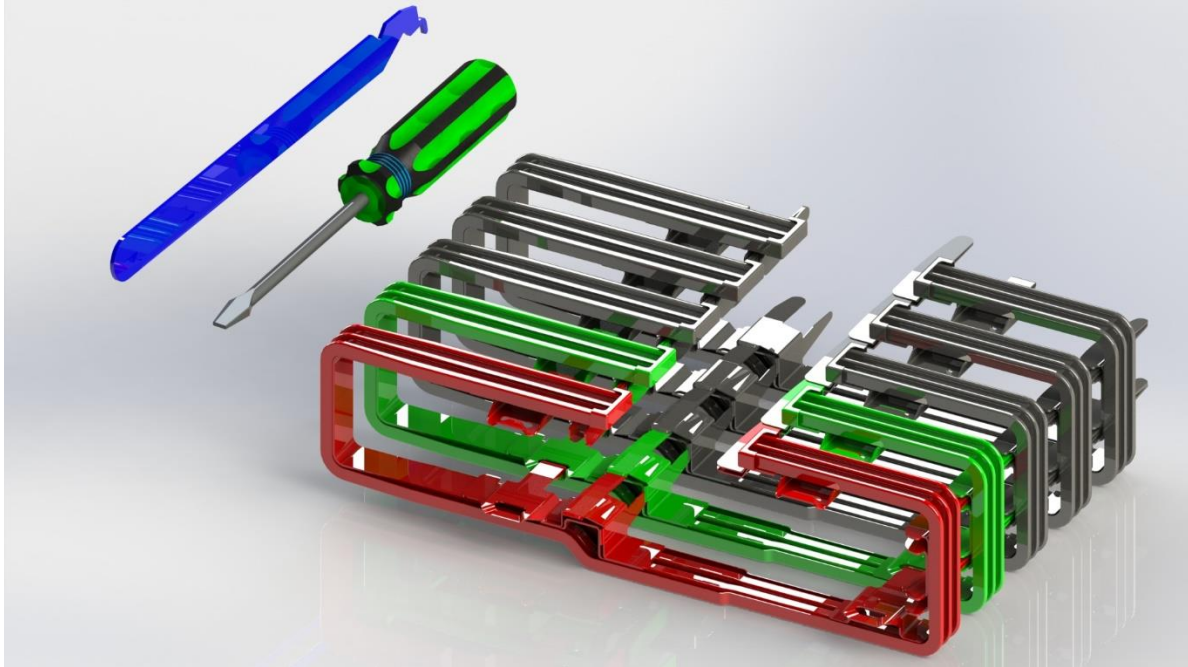

Step 1 – Press the red and green links together so the lip of the red connector clip is clear of the green connector opening.

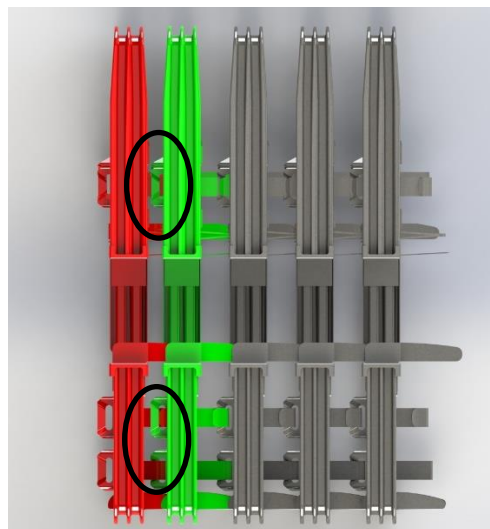
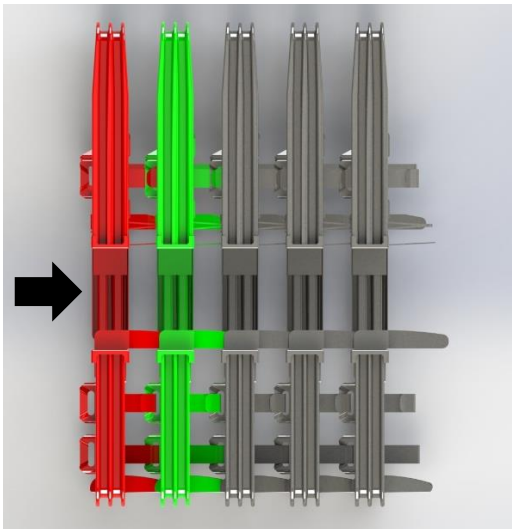

25MM Disassembly – Assembly Instructions

View A – The circle shows the location the blue separation tool will be inserted between the green connector opening and the red connector clip.

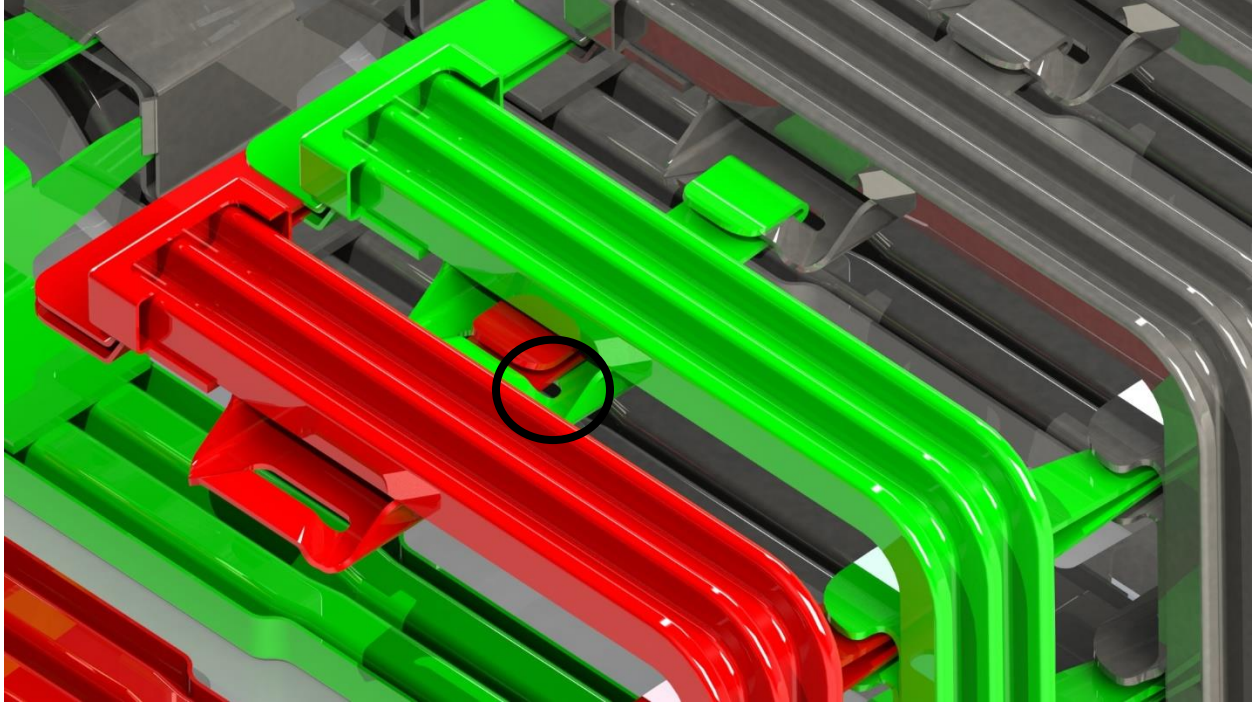

Step 2 – Insert the point of the blue separation tool into the green connector opening next to the red connector clip.

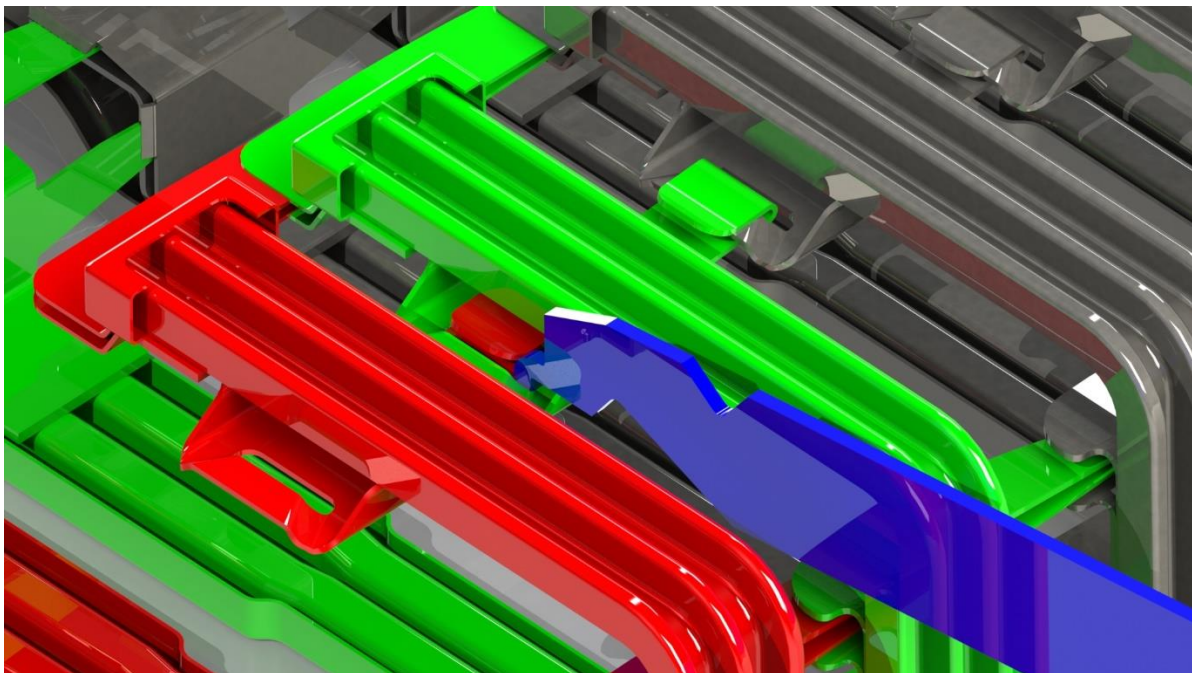

25MM Disassembly – Assembly Instructions

Step 3 – Rotate the blue separation tool over the red connector clip while engaged in the opening of the green connector.

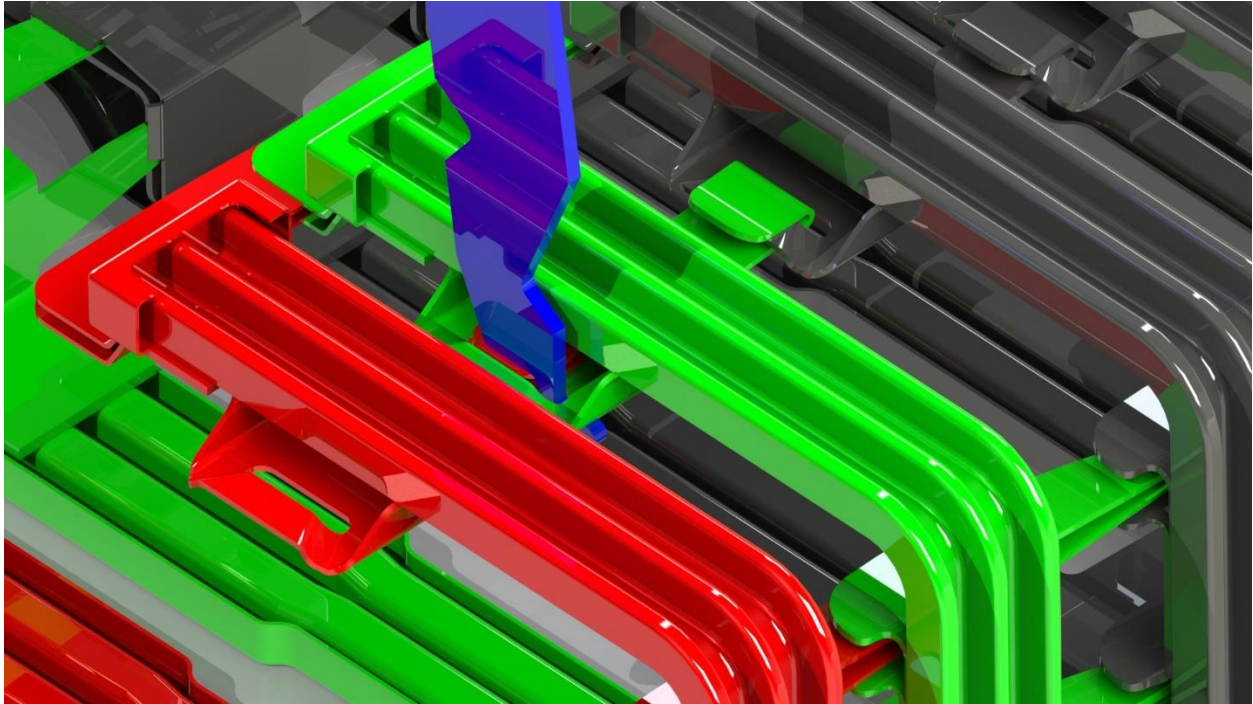

Step 4 – While holding the red connector clip down with the blue separation tool use a flat head screw driver against the green link and push out the red link to separate the red connector from the green connector.

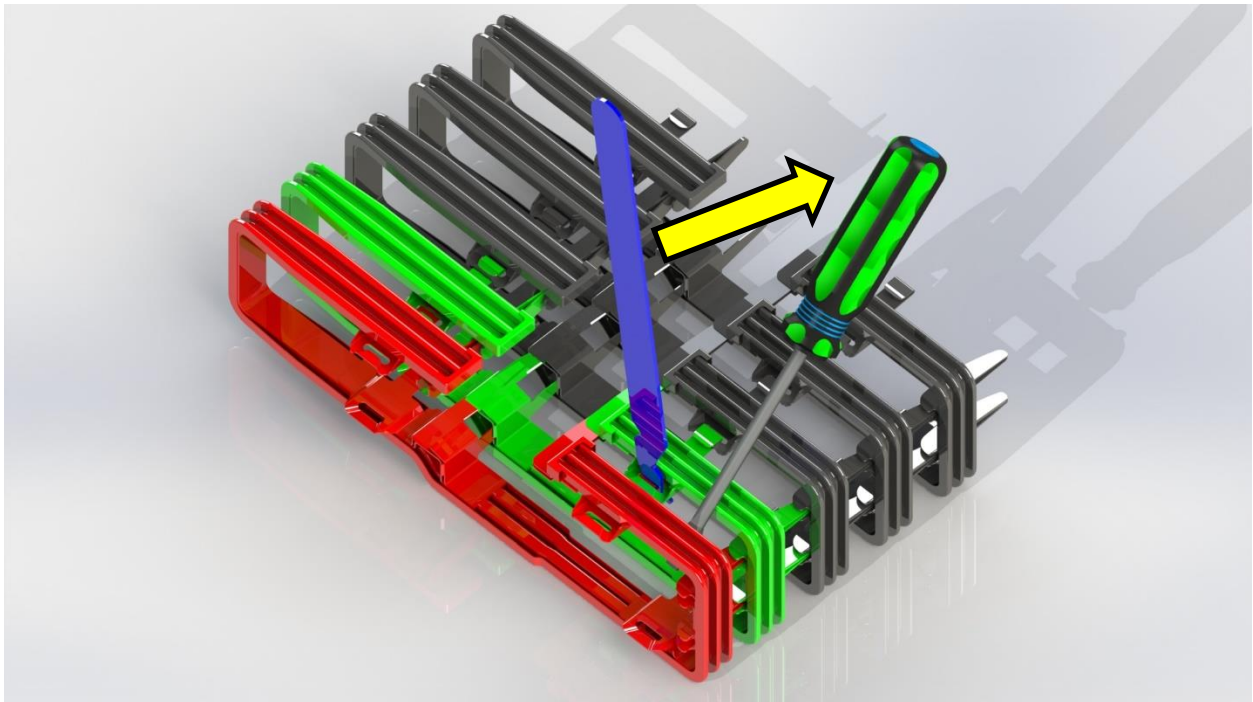

25MM Disassembly – Assembly Instructions

Step 5 – Once the red connector clip is free of the green connector opening pull the blue separation tool from the green connector opening.

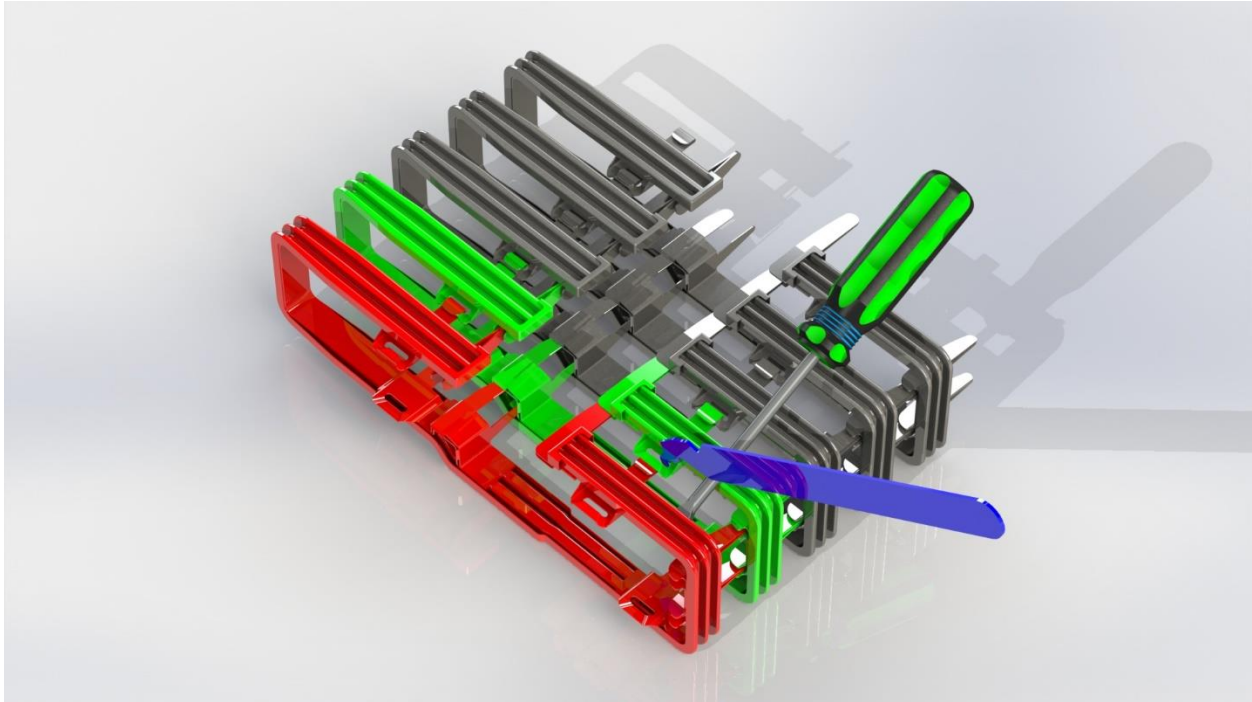

Step 6 – While removing the blue separation tool from the green connector use the screw driver to make sure the links stay disassembled. Do the same process for the other three connectors.

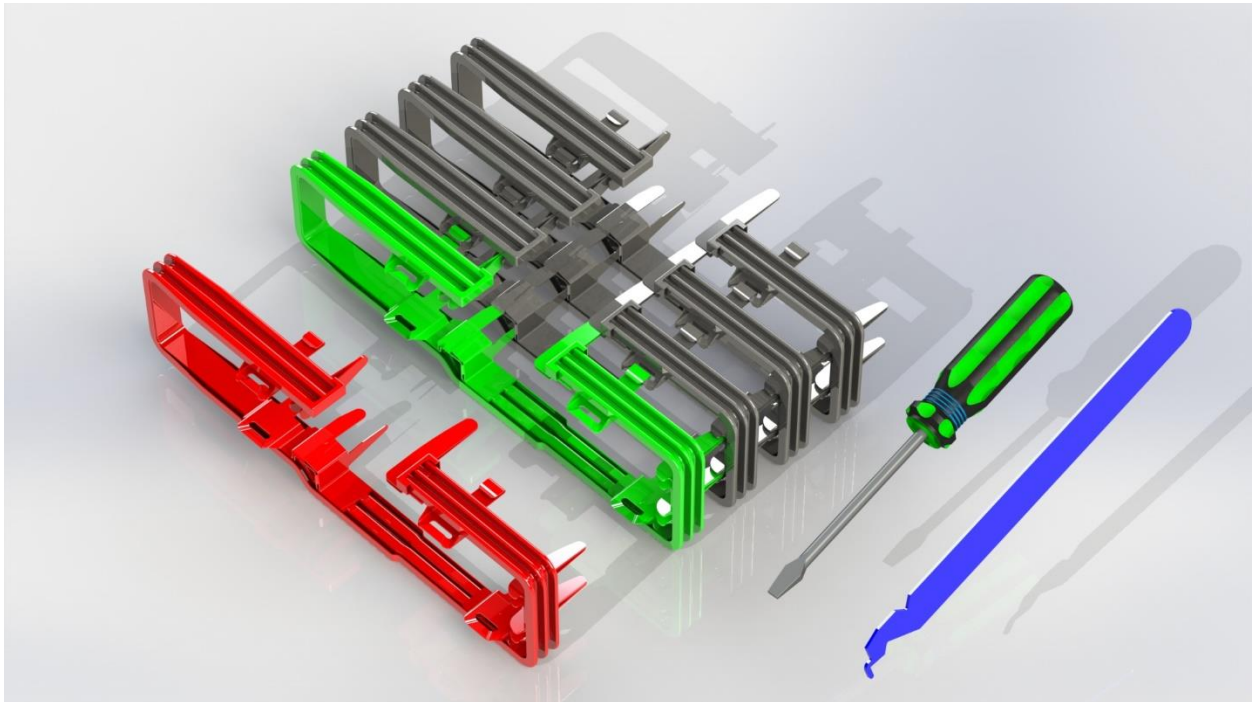

25MM Assembly – Disassembly Instructions

Assembly

Step 1 – Guide liners 1, 2, 3, and 4 on the red link into the opening corresponding openings in the liners on the green link. See the other connected links as an example. Insert the connectors 5-8 on the red link into the corresponding connectors in the green link until they all click in.

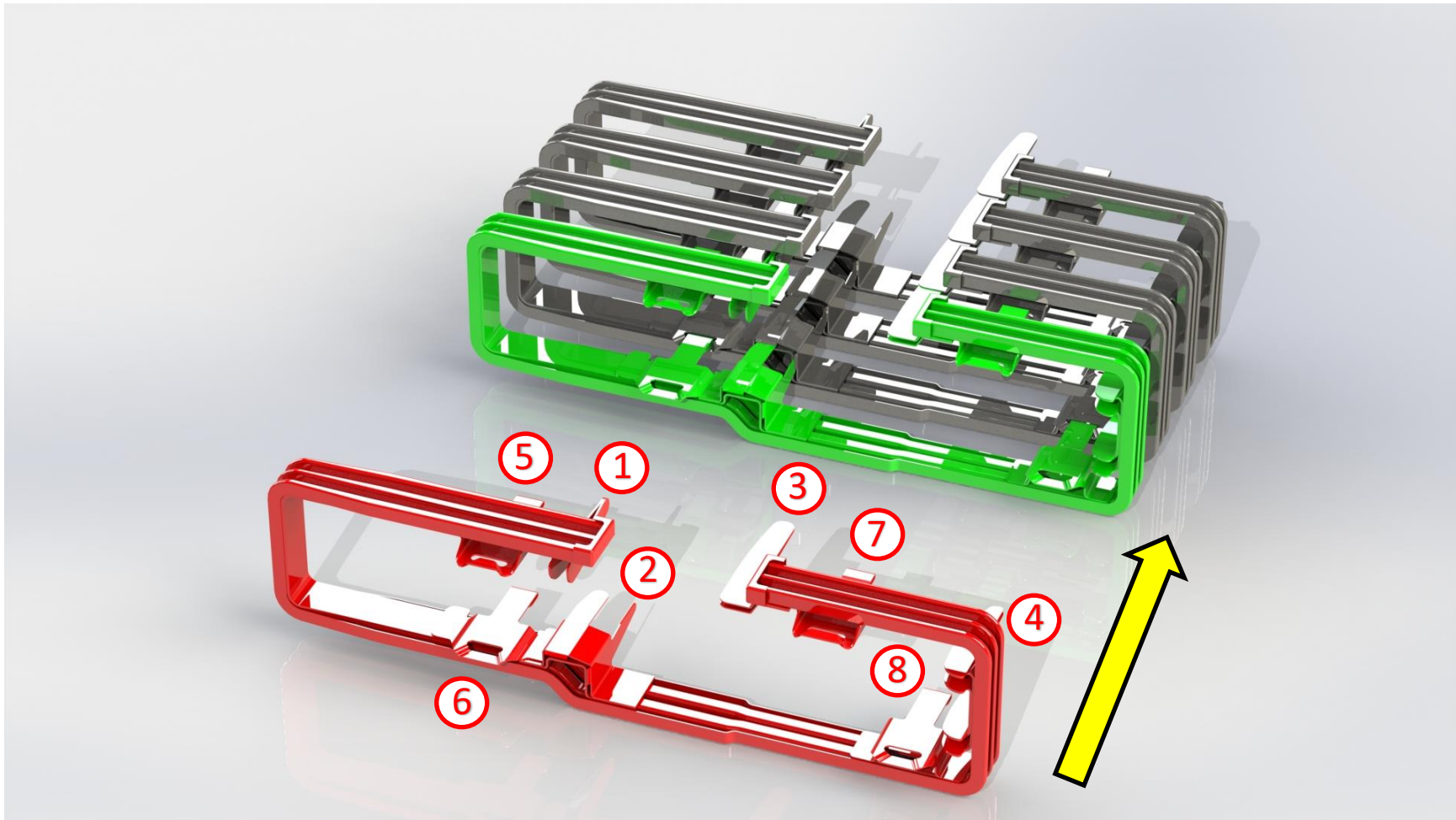

25MM Assembly – Disassembly Instructions

Assembly

Step 1 – Alternate view. Note that there are alternate versions of the 25MM link that might have an alternate amount of connectors/liners.

